

THE NEXT GENERATION STEEL WINDOW AND DOOR SYSTEM IS HERE



Introducing Crittall  
Windows' latest steel  
window and door range:  
**Corporate W20 TE<sup>®</sup>**

A thermally enhanced evolution of Crittall Windows' iconic Corporate W20<sup>®</sup> rolled steel window and door system. Able to attain impressive  $U_w$  &  $U_d$  values of just  $1.4 \text{ W/m}^2 \text{ K}$ , this new system is a real gamechanger in the steel window and door market.

For more information, contact us on

**Call: 01376 530 800**

E: [hq@crittall-windows.co.uk](mailto:hq@crittall-windows.co.uk)  
[www.crittall-windows.co.uk](http://www.crittall-windows.co.uk)

**CRITTALL<sup>®</sup>**

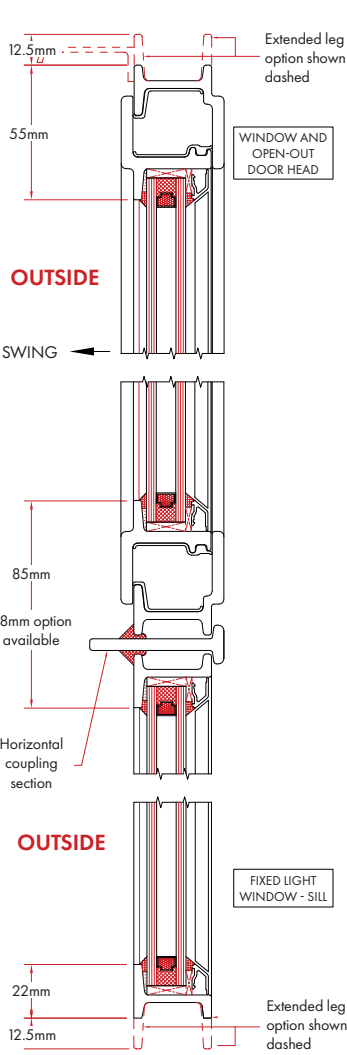

### Generic Thermally Broken Steel System

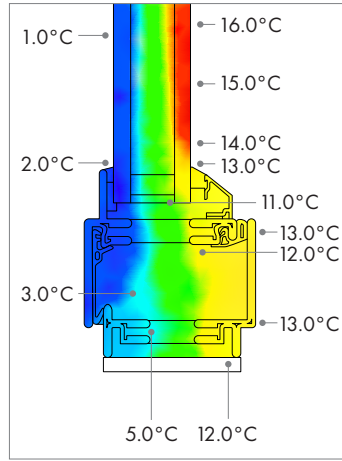

### Corporate W20 TE

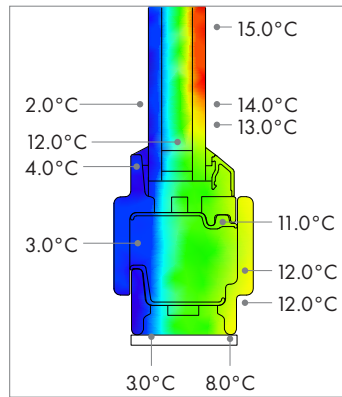

Thermal gradients produced using Dartwin Frame Simulator PRO software to ISO 10077-2:2017

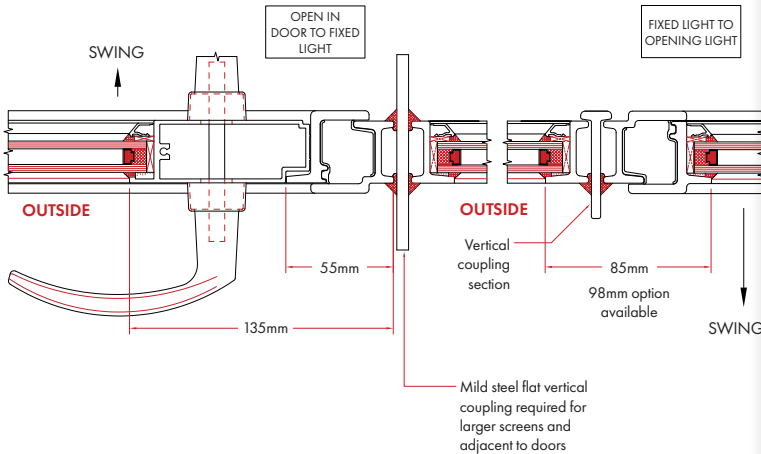

# Reasons to choose Corporate W20 TE®



#### INCREASED PERFORMANCE

The system not only achieves a U value as low as 1.4 W/m<sup>2</sup> K but also achieves a thermal gradient across the profile equivalent to that of a thermally broken steel section.



#### SLIM SIGHTLINES

Properties will be flooded with natural light as Corporate W20 TE® features incredibly slim sightlines synonymous with windows and doors created by Crittall Windows.



#### UNRIVALLED DURABILITY

Manufactured from high quality steel means Corporate W20 TE® windows and doors offer unrivalled strength and durability and boast a life expectancy in excess of 60 years.



#### INCREDIBLE SUSTAINABILITY

Made from 100% recycled steel makes Corporate W20 TE® one of the most sustainable and environmentally friendly steel systems available in the market.



#### IMPRESSIVE VERSATILITY

Corporate W20 TE® can be manufactured to suit contemporary or traditional building styles thanks to its impressive versatility and design flexibility.



#### BESPOKE CUSTOMISATION OPTIONS

All Corporate W20 TE® systems are galvanized and powder coated in any RAL, BS or bespoke shade to perfectly suit the style of any commercial or residential project.



#### SUPERB WEATHER PERFORMANCE

Corporate W20 TE® features innovative co-extruded dual weather seals which deliver superior weather performance, helping to secure this product's high-performance credentials.



#### BUILDING REGULATION COMPLIANT

Naturally, Corporate W20 TE® meets Approved Document L with U<sub>w</sub> & U<sub>d</sub> values of 1.4 W/m<sup>2</sup> K.

## The next generation of steel windows and doors

At Crittall Windows, our team of experts are dedicated to delivering excellence and we're incredibly proud of this latest steel system that not only looks fantastic but delivers exceptional performance.

Design the future with this incredibly energy efficient, highly secure steel system that will redefine the industry.

For more information, contact us on

# CRITTALL®

Call: 01376 530 800

E: [hq@crittall-windows.co.uk](mailto:hq@crittall-windows.co.uk)  
[www.crittall-windows.co.uk](http://www.crittall-windows.co.uk)